

A2 INSTALLATION DRAWING

If this document is printed in hardcopy, it is for information use only and therefore is not subject to updating controls. Always refer to viewer for latest issue.

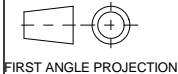

THIS DRAWING IS CONFIDENTIAL AND IS SUPPLIED ON THE EXPRESS CONDITION THAT IT SHALL NOT BE LOANED OR COPIED OR DISCLOSED TO ANY OTHER PERSON OR USED FOR ANY OTHER PURPOSE WITHOUT THE WRITTEN CONSENT OF AP RACING LTD.



AP Racing
Wheler Road
Coventry
CV3 4LB

Tel: +44 024 7663 9595
Fax: +44 024 7663 9559
e-mail: sales@apracings.co.uk
Web site: http://www.apracings.com

© AP Racing Ltd. 2016

Issue No.	Date & No.	Alterations		Zone	Initials
		Particulars			
01	05/10/16 B7630	FIRST ISSUE			CH
02	18/12/17 B7801	CP9093-905 ADDED			CH

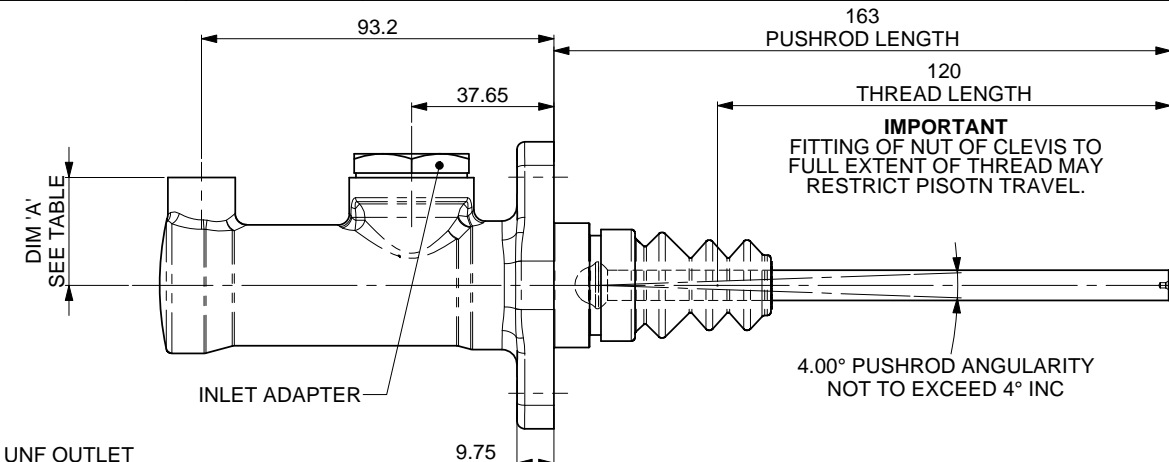
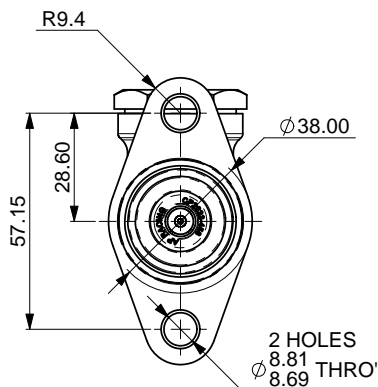

GENERAL DESCRIPTION:
CENTRE VALVE MASTER CYLINDER FOR USE IN ABS AND HIGH PRESSURE APPLICATIONS. CP9093 MASTER CYLINDERS ARE SUPPLIED WITH 7/16" x 20 UNF THREADED INLETS.

AVERAGE WEIGHT.....370g
FULL STROKE.....30mm
TRAVEL TO CUT-OFF
SHORT.....0.68-1.09mm
(0.027"-0.043")

THREADS
INLET.....7/16" x 20 UNF
OUTLET.....3/8" x 24 UNF
BODY MATERIAL.....ALUMINIUM ALLOY
TYPICAL APPLICATIONS.....ABS

SEE SHEET 3 FOR PUSHROD DETAILS AND INLET OPTIONS.

3/8" x 24 UNF OUTLET AEROQUIP ADAPTER AVAILABLE

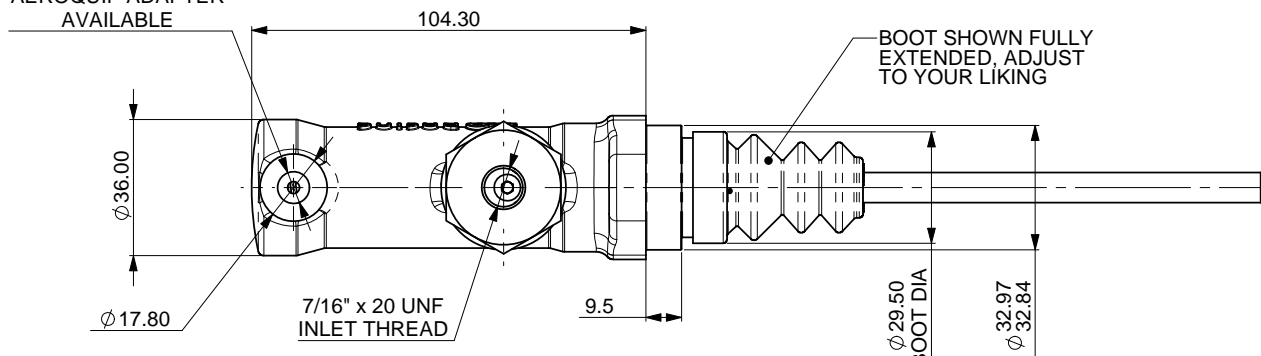

AVAILABLE SIZES OF CYLINDER

PART NUMBER	BORE SIZE	DIM 'A'	SHEET No.	TIE WRAP	REPAR KIT
CP9093-90	Ø15.9 (5/8")	25.40	SHEET 1	BLACK	CP7198-90RK
CP9093-905	Ø16.8	25.9		BLACK & YELLOW	CP7198-905RK
CP9093-91	Ø17.8 (0.70")	26.4		BLUE	CP7198-91RK
CP9093-92	Ø19.1 (3/4")	27.0		GREEN	CP7198-92RK
CP9093-93	Ø20.6 (13/16")	27.8		ORANGE	CP7198-93RK
CP9093-94	Ø22.2 (7/8")	28.6		RED	CP7198-94RK
CP9093-95	Ø23.8 (15/16")	29.4	SHEET 2	WHITE	CP7198-95RK
CP9093-96	Ø25.4 (1.0")	30.2		YELLOW	CP7198-96RK

ORDERING

WHEN ORDERING PLEASE STATE WHICH PUSHROD THREAD TYPE YOU REQUIRE, e.g.
CP9093-90PRM163 - METRIC - M8x1.25
CP9093-90PRT163 - IMPERIAL - 5/16" UNF
PLEASE ALSO STATE WHICH INLET TYPE YOU REQUIRE.

AP RACING TECHNICAL SECTION WILL BE PLEASED TO ADVISE ON THE MOST SUITABLE EQUIPMENT FOR ANY APPLICATION.

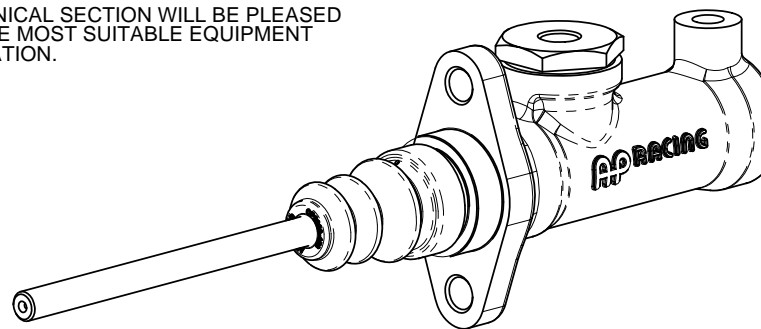

SCALE 1:1	SHEET 1 OF 3
DRAWN	C Homeyard
APPROVED	
DERIVED FROM	CP7198-1CD
TITLE	30.0mm STROKE PUSH TYPE MASTER CYLINDER
DRG NO.	CP9093-1CD

A2 INSTALLATION DRAWING

If this document is printed in hardcopy, it is for information use only and therefore is not subject to updating controls. Always refer to viewer for latest issue.

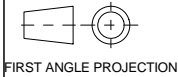

THIS DRAWING IS CONFIDENTIAL AND IS SUPPLIED ON THE EXPRESS CONDITION THAT IT SHALL NOT BE LOANED OR COPIED OR DISCLOSED TO ANY OTHER PERSON OR USED FOR ANY OTHER PURPOSE WITHOUT THE WRITTEN CONSENT OF AP RACING LTD.



AP Racing
Wheler Road
Coventry
CV3 4LB

Tel: +44 024 7663 9595
Fax: +44 024 7663 9559
e-mail: sales@apracing.co.uk

© AP Racing Ltd. 2016

Web site: <http://www.apracing.com>

Issue No.	Date & No.	Alterations Particulars	Zone	Initials
-	-	SEE SHEET 1 FOR ISSUE INFORMATION.	-	-

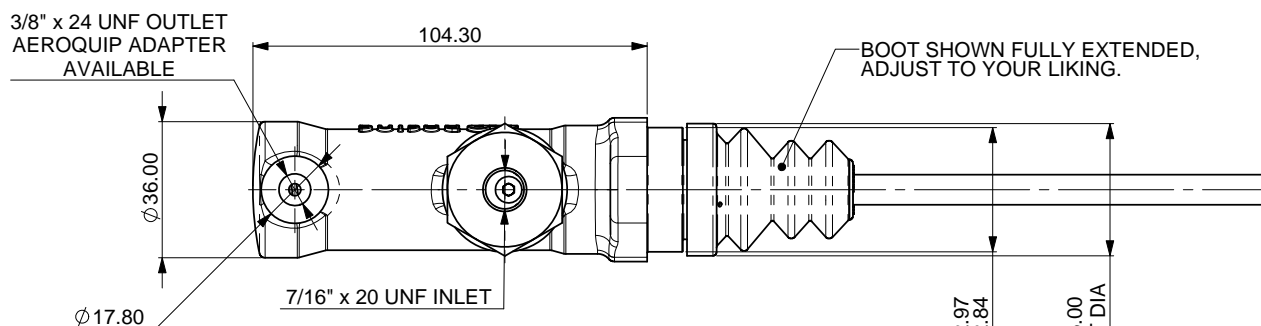
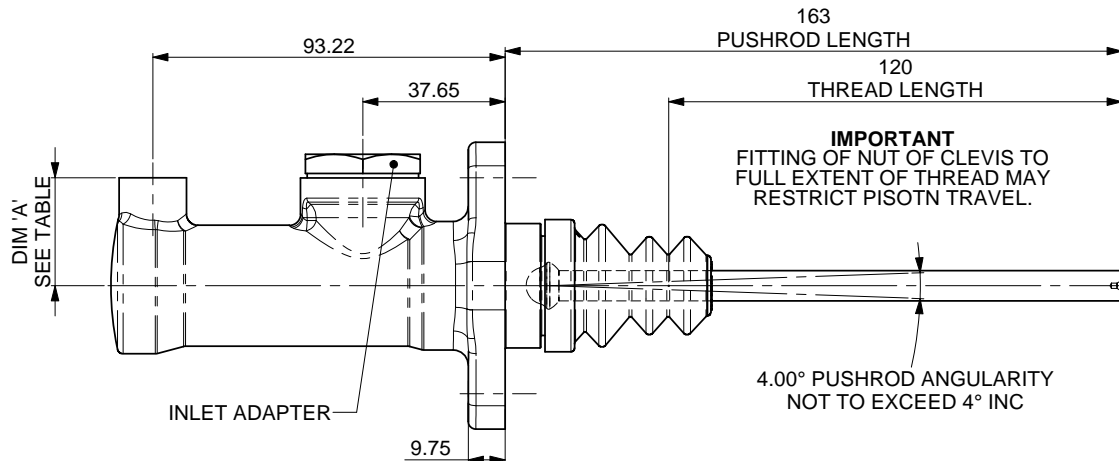
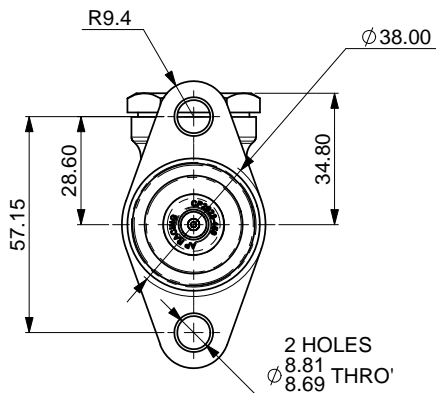

GENERAL DESCRIPTION:

CENTRE VALVE MASTER CYLINDER FOR USE IN ABS AND HIGH PRESSURE APPLICATIONS. CP7198 MASTER CYLINDERS ARE SUPPLIED WITH M12x1.0 THREADED INLETS.

AVERAGE WEIGHT.....370g
FULL STROKE.....30mm
TRAVEL TO CUT-OFF
SHORT.....0.68-1.09mm
(0.027"-0.043")

THREADS
INLET.....7/16" x 20 UNF
OUTLET.....3/8" x 24 UNF
BODY MATERIAL.....ALUMINIUM ALLOY
TYPICAL APPLICATIONS.....ABS

SEE SHEET 3 FOR PUSHROD DETAILS AND INLET OPTIONS

AVAILABLE SIZES OF CYLINDER				
PART NUMBER	BORE SIZE	DIM 'A'	TIE WRAP	REPAR KIT
CP9093-95	Ø23.8 (15/16")	29.4	WHITE	CP7198-95RK
CP9093-96	Ø25.4 (1.0")	30.2	YELLOW	CP7198-96RK

ORDERING

WHEN ORDERING PLEASE STATE WHICH PUSHROD THREAD TYPE YOU REQUIRE, e.g.
CP9093-90PRM163 - METRIC - M8x1.25
CP9093-90PRT163 - IMPERIAL - 5/16" UNF
PLEASE ALSO STATE WHICH INLET TYPE YOU REQUIRE.

ALL CP9093 MASTER CYLINDERS ARE SUPPLIED WITH A PUSHROD OF LENGTH 163 FROM THE MOUNTING FLANGE. THIS MUST BE CUT DOWN IF YOU REQUIRE A SHORTER LENGTH.

AP RACING TECHNICAL SECTION WILL BE PLEASED TO ADVISE ON THE MOST SUITABLE EQUIPMENT FOR ANY APPLICATION.

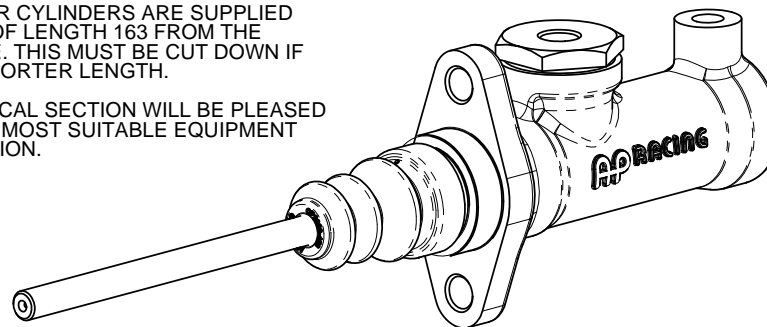

SCALE 1:1	SHEET 2 OF 3
DRAWN	C Homeyard
APPROVED	
DERIVED FROM	CP7198-1CD
TITLE	30.0mm STROKE PUSH TYPE MASTER CYLINDER
DRG NO.	CP9093-1CD

A2 INSTALLATION DRAWING

If this document is printed in hardcopy, it is for information use only and therefore is not subject to updating controls. Always refer to viewer for latest issue.

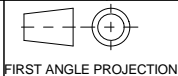

THIS DRAWING IS CONFIDENTIAL AND IS SUPPLIED ON THE EXPRESS CONDITION THAT IT SHALL NOT BE LOANED OR COPIED OR DISCLOSED TO ANY OTHER PERSON OR USED FOR ANY OTHER PURPOSE WITHOUT THE WRITTEN CONSENT OF AP RACING LTD.



AP Racing
Wheler Road
Coventry
CV3 4LB

Tel: +44 024 7663 9595
Fax: +44 024 7663 9559
e-mail: sales@ap racing.co.uk

© AP Racing Ltd. 2016

Web site: <http://www.ap racing.com>

Issue No.	Date & No.	Alterations Particulars	Zone	Initials
-	-	SEE SHEET 1 FOR ISSUE INFORMATION.	-	-

PUSHROD
CP9093 MASTER CYLINDERS ARE SUPPLIED WITH A PUSHROD LENGTH OF 163mm. CUSTOMERS SHOULD CUT THE PUSHROD DOWN TO THE REQUIRED SIZE FOR THEIR ASSEMBLY.

PUSHROD TYPES:

- PRT - PUSH ROD THREADED 5/16" UNF
- PRM - PUSH ROD THREADED M8x1.25

PUSHROD LENGTHS ARE MEASURED FROM THE MOUNTING FLANGE AS SHOWN.

PUSHROD EXTENSIONS THAT GIVE A TOTAL LENGTH OF OVER 200mm ARE NOT RECOMMENDED. IT IS THE CUSTOMERS RESPONSIBILITY TO CHECK SUITABILITY OF PUSHROD AND EXTENTION PIECES TO TAKE APPLIED LOADS.

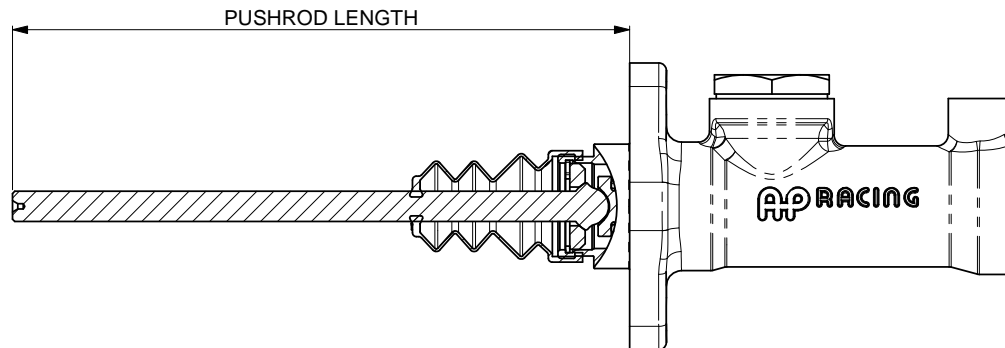

IMPORTANT NOTE

CP9093 MASTER CYLINDERS ARE INDIVIDUALLY SHIMMED DURING ASSEMBLY TO MINIMISE FREE PLAY. THEREFORE PUSHRODS SHOULD NOT BE SWITCHED BETWEEN INDIVIDUAL MASTER CYLINDER ASSEMBLIES.

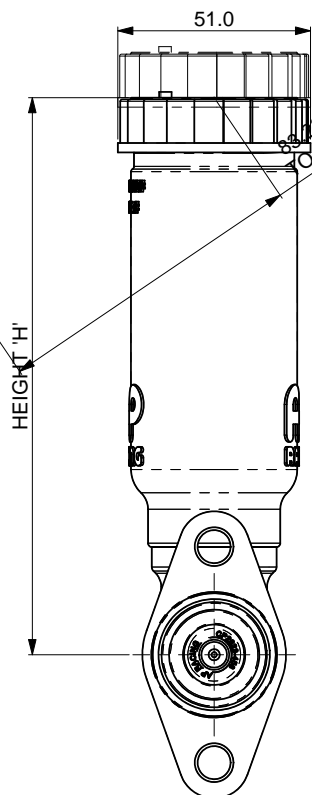

51.0
12.43
8.13 (0.48") MIN TO REMOVE CAP

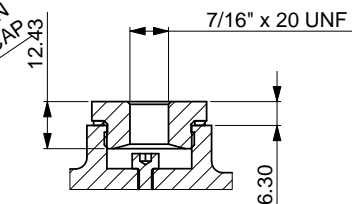

INLET TYPE 'B'
7/16" x 20 UNF ADAPTER COMES FITTED TO ALL CP9093 MASTER CYLINDERS AS STANDARD.

INLET TYPE 'C'

TO FIT CP4709 TYPE RESEVOIRS THE INLET ADAPTER AND COPPER GASKET ARE TO BE REMOVED. FITTING INSTRUCTIONS SUPPLIED WITH RESEVOIR.

RESEVOIR PART No.	HEIGHT 'H' mm (in)	DIA 'E' mm (in)	VOLUME cm ³ (in ³)
CP4709-10	198 (7.80")	51 (2.0")	183 (11.1")
CP4709-11	148 (5.83")		123 (7.5")
CP4709-12	108 (4.25")		75 (4.5")

OTHER RESEVOIR OPTIONS AVAILABLE, SEE AP RACING HYDRAULIC ACTUATION CATALOGUE.

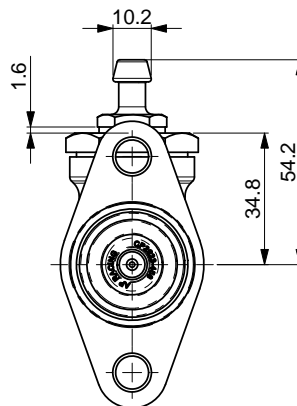

INLET TYPE 'A'
SELECT MASTER CYLINDER WITH INLET TYPE 'B', PLUS INLET ADAPTER KIT PART NUMBER CP4623-2.

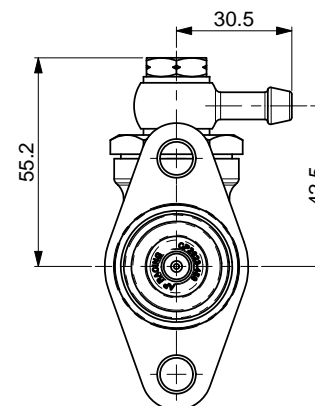

INLET TYPE 'D'
SELECT MASTER CYLINDER WITH INLET TYPE 'B', PLUS INLET ADAPTER KIT PART NUMBER CP4623-6.

SCALE 1:1	SHEET 3 OF 3
DRAWN	C Homeyard
APPROVED	
DERIVED FROM	CP7198-1CD
TITLE 30.0mm STROKE PUSH TYPE MASTER CYLINDER	
DRG NO.	CP9093-1CD