

**B1 ASSEMBLY DRAWING**

IF THIS DOCUMENT IS PRINTED IN HARDCOPY, IT IS FOR INFORMATION USE ONLY AND THEREFORE IS NOT SUBJECT TO UPDATING CONTROLS. ALWAYS REFER TO SOLIDWORKS VIEWER FOR LATEST ISSUE



THIS DRAWING IS CONFIDENTIAL AND IS SUPPLIED ON THE EXPRESS CONDITION THAT IT SHALL NOT BE LOANED OR COPIED OR DISCLOSED TO ANY OTHER PERSON OR USED FOR ANY OTHER PURPOSE WITHOUT THE WRITTEN CONSENT OF AP RACING LTD.

**AP RACING**  
 Wheler Road  
 Coventry  
 CV3 4LB  
 Tel: +44 024 7663 9595  
 Fax: +44 024 7663 9559  
 e-mail: sales@apracings.co.uk  
 Web site: HTTP://www.apracings.com

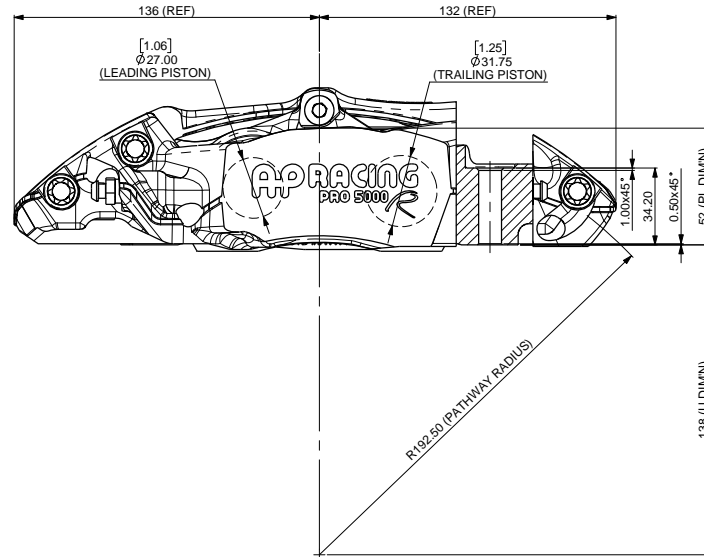
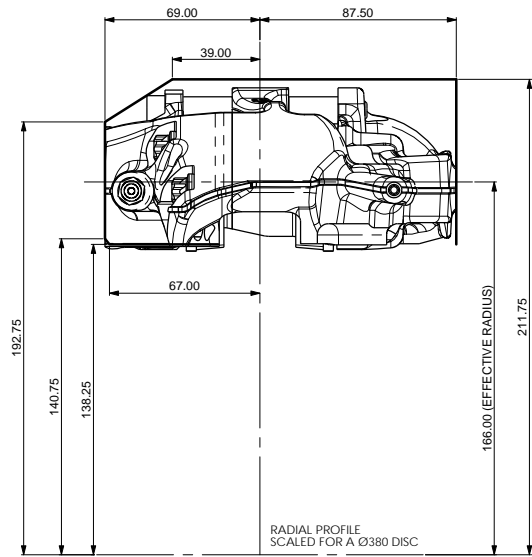

**GENERAL DESCRIPTION**  
 THIS 4 PISTON DIFFERENTIAL BORE CALIPER TO SUIT UP TO Ø380 IRON DISC WITH A THICKNESS OF 28-32mm.

**APPLICATION**  
 GENERAL USE CALIPER.

**TECHNICAL INFORMATION**  
 TOTAL PISTON AREA: 27.2cm<sup>2</sup>  
 BODY MATERIAL: ALUMINIUM ALLOY  
 PISTON MATERIAL: STAINLESS STEEL

ASSEMBLY WEIGHT (LESS PADS): 2.21Kg  
 MINIMUM DISC & PAD STACK: 40MM

**INSTALLATION INFORMATION**  
 DISC & CALIPER MOUNTING TOLERANCES TO BE SUCH THAT THE DISC IS CENTRAL TO THE CALIPER TO WITHIN ±0.5mm. DISC DIAMETRAL CLEARANCE SHOULD BE 2.5mm NOMINAL FROM DISC O/D TO PATHWAY.

**KEY TO DIMENSIONS**  
 'PL' DIMN : TOP OF PAD MATERIAL TO MOUNTING FACE.  
 'U' DIMN : WHEEL CENTRE LINE TO CALIPER  
 MOUNTING FACE = (DISC Ø/2) - PL DIMN

AP RACING TECHNICAL SECTION WILL BE PLEASED TO ADVISE ON THE MOST SUITABLE EQUIPMENT FOR ANY PARTICULAR APPLICATION.

**CALIPER PART NUMBERS**  
 CP9450-2S4L - RIGHT HAND  
 CP9450-3S4L - LEFT HAND

**RECOMMENDED DISC AND PAD OPTIONS AVAILABLE**  
 D46 DISC AND PAD COMBINATION

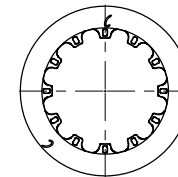

CP5772-1010/1GA Ø378x32 12F 72V 6.26Kg  
 CP5914-1167G12 Ø378x28 12B 48V 6.20Kg  
 CP5914-1101G8 Ø378x28 12F 48V 6.28Kg

SEE CUSTOMER DRAWING FOR FULL DETAIL

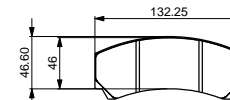

**CP3215D46 PAD FAMILY**  
 PAD THICKNESS - 16.75mm  
 PAD AREA - 50.89cm<sup>2</sup>  
 PAD VOLUME - 85.24cm<sup>3</sup>

**OPTIMUM BLEED POSITIONING**

FOR OPTIMUM BLEED, THE CALIPER SHOULD BE INSTALLED IN THE LEADING OR TRAILING POSITION BETWEEN THE ANGLES SHOWN

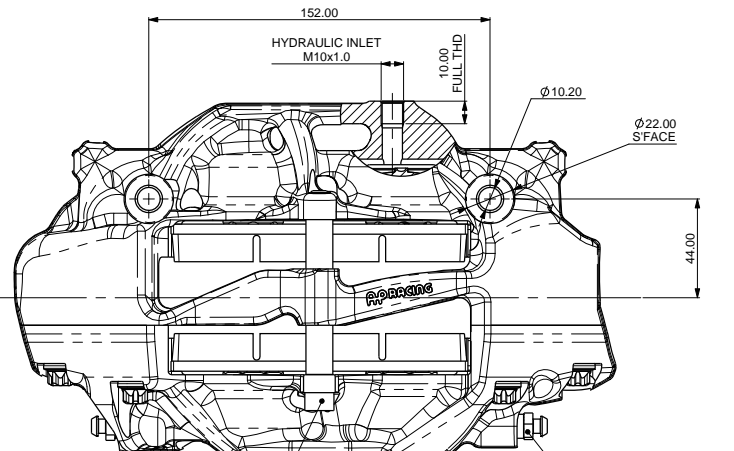
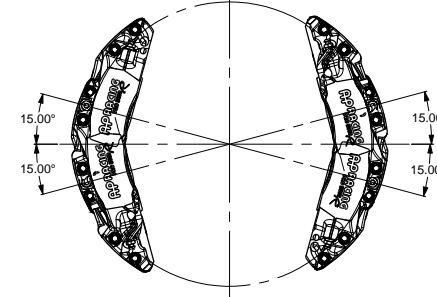

PAD RETAINING BOLT SHOULD BE TIGHTENED TO A TORQUE OF 13.1Nm (9.7 Lbs ft)

BLEED SCREW TIGHTENING TORQUE 17.0 Nm (12.5 Lbs ft)

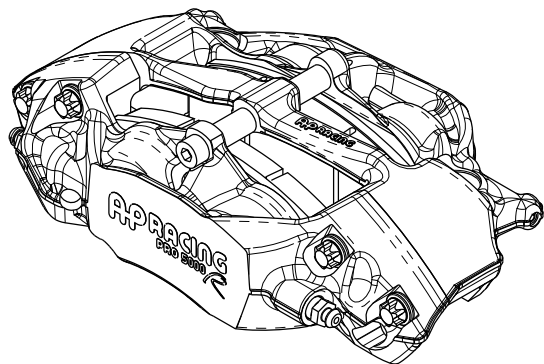

Issue No	Alterations		Zone	Initials
	Date & No.	Particulars		
1A	09/06/16 87478	FIRST ISSUE		

SCALE 1:1	SHEET 1 OF 2
DRAWN N STEVENS	
APPROVED	
DERIVED FROM	
TITLE 4 POT PRO5000 R CALIPER INSTALLATION	
DRG NO.	CP9450-1CD

**B1 ASSEMBLY DRAWING**

IF THIS DOCUMENT IS PRINTED IN HARDCOPY, IT IS FOR INFORMATION USE ONLY AND THEREFORE IS NOT SUBJECT TO UPDATING CONTROLS. ALWAYS REFER TO SOLIDWORKS VIEWER FOR LATEST ISSUE



THIS DRAWING IS CONFIDENTIAL AND IS SUPPLIED ON THE EXPRESS CONDITION THAT IT SHALL NOT BE LOANED OR COPIED OR DISCLOSED TO ANY OTHER PERSON OR USED FOR ANY OTHER PURPOSE WITHOUT THE WRITTEN CONSENT OF AP RACING LTD.



AP Racing  
Wheler Road  
Coventry  
CV3 4LB  
Tel: +44 024 7663 9595  
Fax: +44 024 7663 9559  
e-mail: sales@apracing.co.uk  
Web site: HTTP://www.apracing.com

REF	PART NUMBER	DESCRIPTION	QTY / CALIPER	FITTING NOTES
1	CP3880-1	M10 BLEED SCREW KIT	2	TIGHTENING TORQUE - 17Nm
2	CP9440-116	M5 BUTTON SCREW	2	APPLY A 1-2MM DROP OF LOCTITE 270 TO THE 2ND FROM LAST THREAD WHEN FITTING. TIGHTENING TORQUE - 3.7Nm
3	CP9444-112	RH WEARPLATE	1	APPLY 736 RTV SILICONE SPARINGLY BEHIND THE ABUTMENT PLATE ENSURING ENTIRE CONTACT FACE IS COVERED.  APPLY PRESSURE TO ABUTMENT PLATE WHEN FITTING TO ENSURE MINIMUM FILM THICKNESS AND AVOID ANY GAP.
4	CP9444-113	LH WEARPLATE		ENSURE ABUTMENT PLATE SITS CORRECTLY AGAINST CALIPER BODY BEFORE FITTING RETAINING SCREW.
5	CP9450-104	Ø27MM SST PISTON	2	
6	CP9445-108	Ø1 1/4" SST PISTON	2	
7	CP8518-CE	PISTON SEAL KIT	1	REFER TO PUBLICATION REF: P14.290 & P14.220
8	CP3596-112ST	M8 CAP SCREW	1	TIGHTENING TORQUE - 13.1Nm
9	CP9440-110	PAD RETAINER TUBE	2	

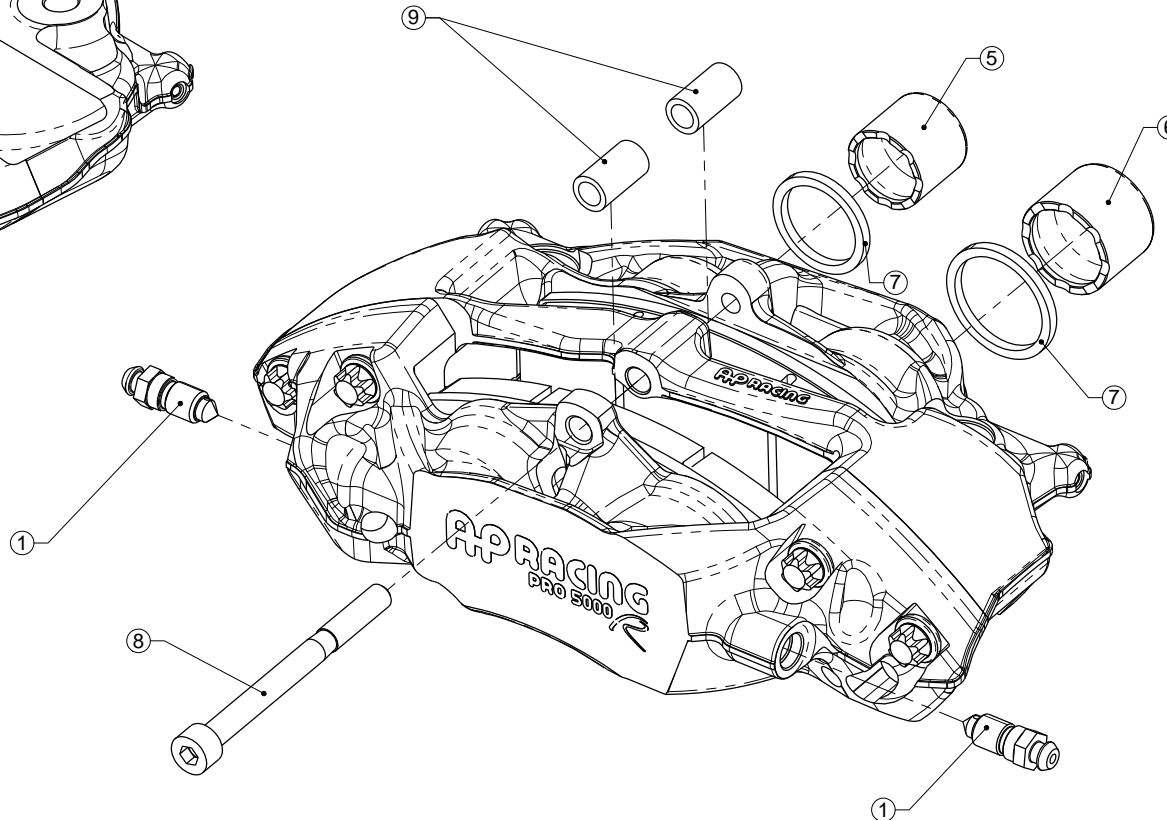
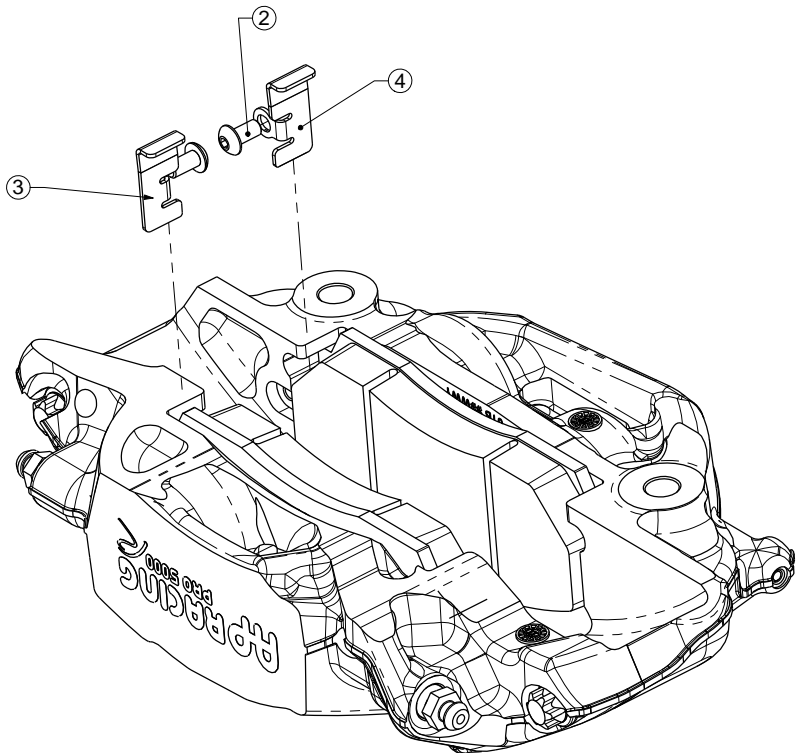

Issue No.	Alterations		
	Date & No.	Particulars	Zone / Initials
-	-	SEE SHEET 1 FOR ISSUE INFORMATION.	-

SCALE 1.5:1	SHEET 2 OF 2
DRAWN N STEVENS	
APPROVED	
DERIVED FROM	
TITLE 4 POT PRO5000 R CALIPER INSTALLATION	
DRG NO.	CP9450-1CD