



Before installing this product, check the contents of the kit. If anything is missing, please contact an Öhlins dealer.

<b>Kit Contents</b>	<b>Pcs.</b>
<i>Shock absorber</i>	2
<i>Upper spring seat</i>	2
<i>Dust boot</i>	2
<i>Top mount</i>	2
<i>Bearing spacer (L=10mm)</i>	(2)
<i>Top nut (M12 L=22mm)</i>	(2)
<i>Spring</i>	2
<i>ABS cable bracket (RH)</i>	1
<i>ABS cable bracket (LH)</i>	1
<i>Nut M8</i>	4

**USED FOR BOTH FRONT AND REAR**

<i>C-spanner</i>	1
<i>C-spanner</i>	1
<i>Öhlins sticker</i>	1
<i>Öhlins Owner's Manual</i>	1

Please note that during storage and transportation, especially at high ambient temperature, some of the oil and grease used for assembling may leak and stain the packaging. This is in no way detrimental to the product, wipe off the excess oil/grease with a cloth.

**⚠ Warning!**

*Before installing this product, read the Öhlins Owner's Manual. The shock absorber is an important part of your vehicle and will affect the stability.*

*Shock Absorber Kit for Subaru Impreza (GRB)*

# *SUS MI10 front*

## **Mounting Instructions**



# How to install

## ⚠ Warning!

It is advisable to have an Öhlins dealer install the shock absorber.  
When installing, read your Vehicle Service Manual.



1

Raise the vehicle and put it on jack stands.

## ⚠ Warning!

Ensure that it is securely supported.

2

Remove the front wheels.

3

Loosen the bolts for the lower strut attachments.

## 🖐 Caution!

Support the wheel hubs in an appropriate way on each side of the vehicle so that the brake hose and/or drive shaft joint can not be damaged.

4

Loosen the upper attachment. Remove the original struts from the car.

5

Remove the brake hose brackets from the standard struts.

6

Cut the dust boot 20 mm from the lower end with a pair of scissors according to fig ②.

7

Tighten the lower spring seat and the lock ring to 50 - 60 Nm.  
Fit the dust boot, the spring and the upper spring seat to the strut according to fig ①.  
Fit the bearing spacer, the top mount and the top nut. Tighten the top nut to 35 - 40 Nm.

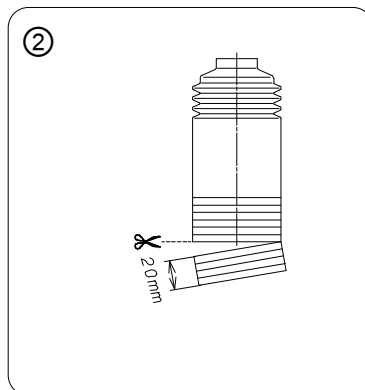
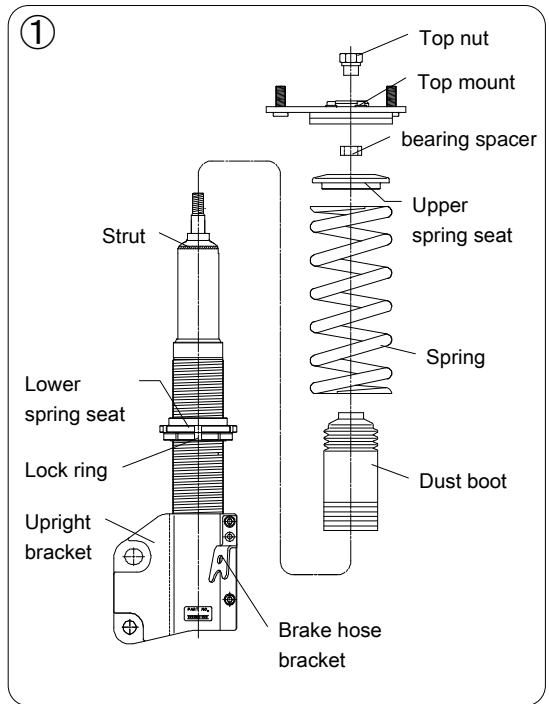

# How to install

**8**

Mount the original brake hose to the Öhlins struts. Tighten the nut to 6 Nm.

**9**

Mount the original ABS cable clamp to the ABS cable bracket according to fig ③. Tighten the bolt to 6 Nm.

## **Note!**

*When tightening the top mount nut, the shock absorber shaft must be held in position with a 5 mm Allen key.*

**10**

Install the Öhlins McPherson struts on the body.

**11**

Fasten the upper attachments.

**12**

Raise the wheel hub with a jack to remove the freeplay of the lower strut attachment bolts before tightening them.

**13**

Tighten the lower strut attachment bolts after mounting the ABS cable bracket according to fig ③.

## **Note!**

*Make sure that all bolts are tightened to the correct torque and that nothing fouls or restricts movement of the strut when it is being fully compressed or extended. Test this over the whole steering range from lock to lock.*

**14**

Make sure that all removed parts are reinstalled in the same way as they were before the installation of the Öhlins shock absorber.

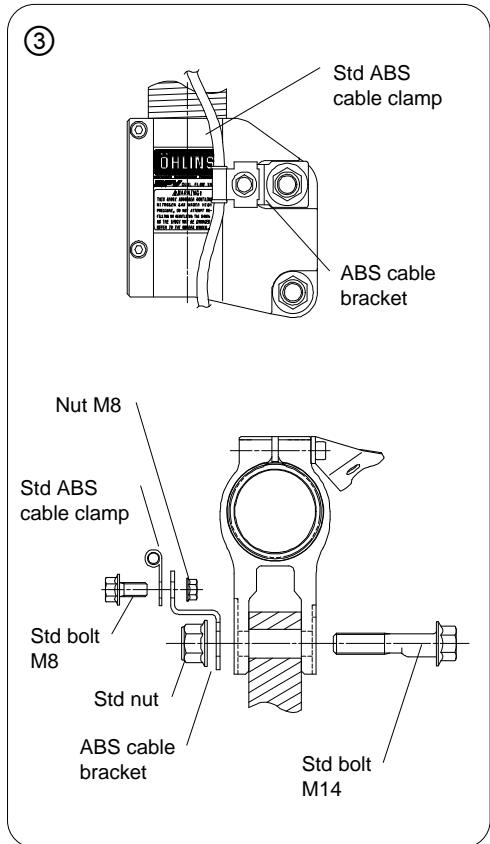

# Adjustments

## ⚠ Warning!

Before driving, always make sure that the basic settings made by Öhlins are according to recommended Set-up Data. Read about adjustments and setting up in the Öhlins Owner's Manual before you make any adjustments. Contact an Öhlins dealer if you have any questions about setting up the shock absorber.

The standard preload is 2 mm from a free length of 200 mm, giving 198 mm installed length, see fig ④.

## Set-up Data

### Recommended set-up

Rebound 10 clicks  
Spring preload 2 mm  
Shock absorber length 369 mm

### Spring

Spec H200, ID65, 90 N/mm

### The actual vehicle height

With both the preload and height adjustments in their standard positions, the vehicle is lowered approximately 20 mm when compared to the original suspension. As the height adjuster is turned one rotation, the position moves 2.0 mm.

## ⚠ Warning!

The adjustment range is the standard position -10 to + 15 mm. If the bracket is moved outside the adjustment range, it may come loose.

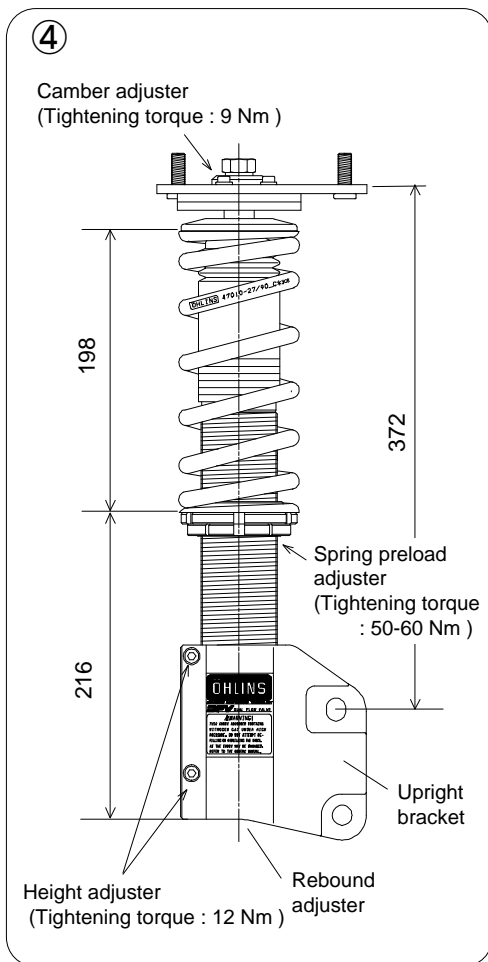

👁 Öhlins products are subject to continuous improvement and development, therefore, although these instructions include the most up-to-date information available at the time of printing, minor updates may occur.

To find the latest information contact your Öhlins distributor. Please consult your Öhlins dealer if you have any questions regarding the contents in this document.



Part no. SUSM10\_1  
Issued 2013-11-15

© Öhlins Racing AB. All rights reserved. Any reprinting or unauthorized use without the written permission of Öhlins Racing AB is prohibited.

Öhlins Racing AB



[www.ohlins.com](http://www.ohlins.com)

Before installing this product, check the contents of the kit. If anything is missing, please contact an Öhlins dealer.



<b>Kit Contents</b>	<b>Pcs.</b>
Shock absorber	2
Dust boot	2
Top mount	2
Spring	2
Bushing spacer	4
Self lock nut M12	2

**MOUNTED ON SHOCK ABSORBER**

Adjuster	2
----------	---

**USED FOR BOTH FRONT AND REAR**

C-spanner	1
C-spanner	1
Öhlins sticker	1
Öhlins Owner's Manual	1

Please note that during storage and transportation, especially at high ambient temperature, some of the oil and grease used for assembling may leak and stain the packaging. This is in no way detrimental to the product, wipe off the excess oil/grease with a cloth.

**⚠ Warning!**

*Before installing this product, read the Öhlins Owner's Manual. The shock absorber is an important part of your vehicle and will affect the stability.*

*Shock Absorber Kit for Subaru Impreza (GRB)*

# *SUS MI10 rear*

## **Mounting Instructions**



# How to install

## ▲ Warning!

It is advisable to have an Öhlins dealer install the shock absorber.

When installing, read your Vehicle Service Manual.



- 1 Raise the vehicle and put it on jack stands.

## ▲ Warning!

Ensure that it is securely supported.

- 2 Remove the rear wheels.
- 3 Remove the lower and the upper attachments and remove the original shock absorbers.
- 4 Cut the dust boot 52 mm from the lower end with a pair of scissors according to fig ②.

- 5 Tighten the lower spring seat and the lock nut to 50 - 60 Nm.  
Fit the bushing spacers, the dust boot, the spring, the top mount and the adjuster according to fig ①. Tighten the self lock nut to 30 Nm.

## 👁 Note!

When tightening the top mount nut, the shock absorber shaft must be held in position with a flat screwdriver.

- 6 Install the Öhlins shock absorbers on the vehicle.

- 7 Fasten the upper attachments.

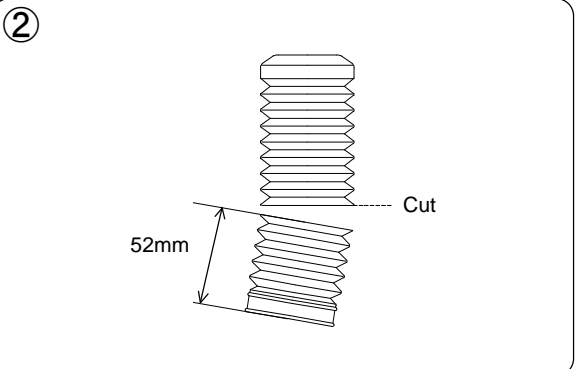
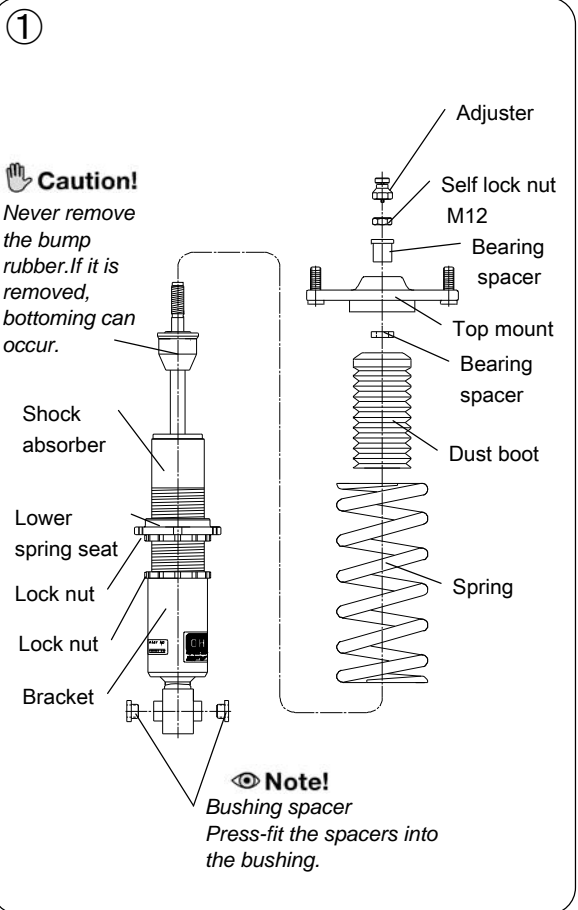

# How to install

## Note!

*Make sure that all bolts are tightened to the correct torque and that nothing fouls or restricts movement of the shock absorber when it is being fully compressed or extended.*

## 8

Make sure that all removed parts are reinstalled in the same way as they were before the installation of the Öhlins shock absorber.

### ③ Left side of vehicle body inside trunk room

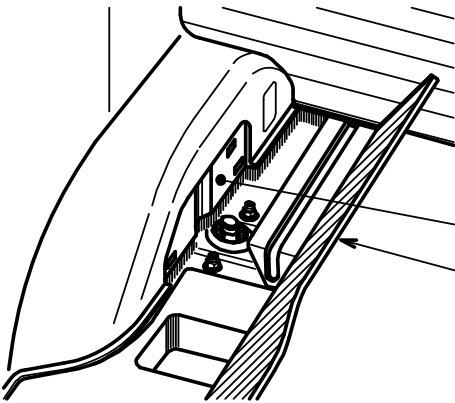

Remove the side panel, because the panel touches the adjuster.

Adjuster is under the cover

# Adjustments

## ⚠ Warning!

Before driving, always make sure that the basic settings made by Öhlins are according to recommended Set-up Data. Read about adjustments and setting up in the Öhlins Owner's Manual before you make any adjustments. Contact an Öhlins dealer if you have any questions about setting up the shock absorber.

The standard preload is 2 mm from a free length of 200 mm, giving 198 mm installed length, see fig ④.

## Set-up Data

### Recommended set-up

Rebound                    10 clicks  
Spring preload         2 mm  
Shock absorber length 392 mm

### Spring

Spec     H200, ID65, 70 N/mm

### The actual vehicle height

With both the preload and height adjustments in their standard positions, the vehicle is lowered approximately 20 mm when compared to the original suspension. As the height adjuster is turned one rotation, the position moves 1.5 mm.

## ⚠ Warning!

The adjustment range is the standard position  $\pm 15$  mm. If the bracket is moved outside the adjustment range, it may come loose.

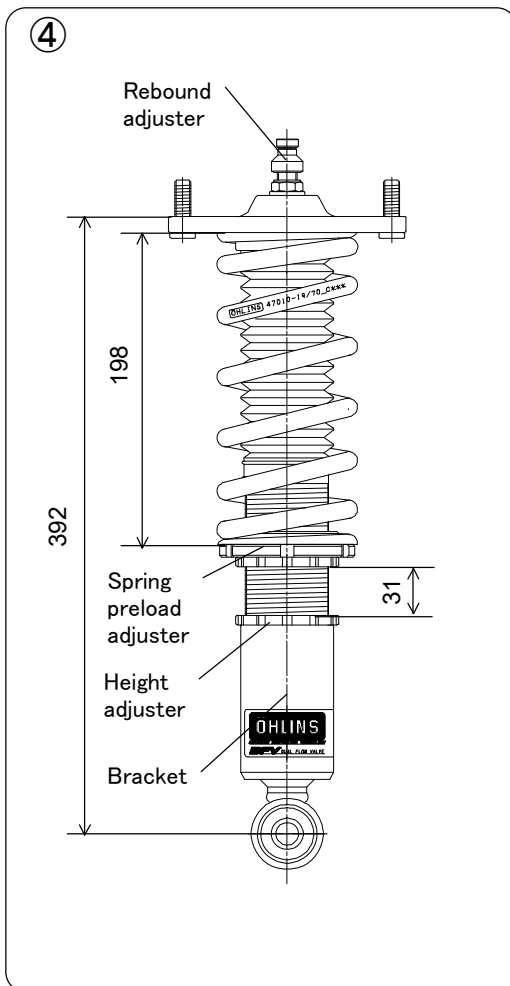

👁 Öhlins products are subject to continuous improvement and development, therefore, although these instructions include the most up-to-date information available at the time of printing, minor updates may occur.

To find the latest information contact your Öhlins distributor. Please consult your Öhlins dealer if you have any questions regarding the contents in this document.



Part no. SUSMI10\_0  
Issued 2009-05-05

© Öhlins Racing AB. All rights reserved. Any reprinting or unauthorized use without the written permission of Öhlins Racing AB is prohibited.

Öhlins Racing AB



[www.ohlins.com](http://www.ohlins.com)